

Noise

*David Johns and Ken Martin
University of Toronto
(johns@eecg.toronto.edu)
(martin@eecg.toronto.edu)*



Interference Noise

- Unwanted interaction between circuit and outside world
- May or may not be random
- Examples: power supply noise, capacitive coupling

Improvement by ...

- Reduced by careful wiring or layout

- These notes do not deal with interference noise.



Inherent Noise

- Random noise — can be reduced but NEVER eliminated
- Examples: thermal, shot, and flicker

Improvement by ...

- Not strongly affected by wiring or layout
 - Reduced by proper circuit DESIGN.
-
- These notes discuss noise analysis and inherent noise sources.



Time-Domain Analysis

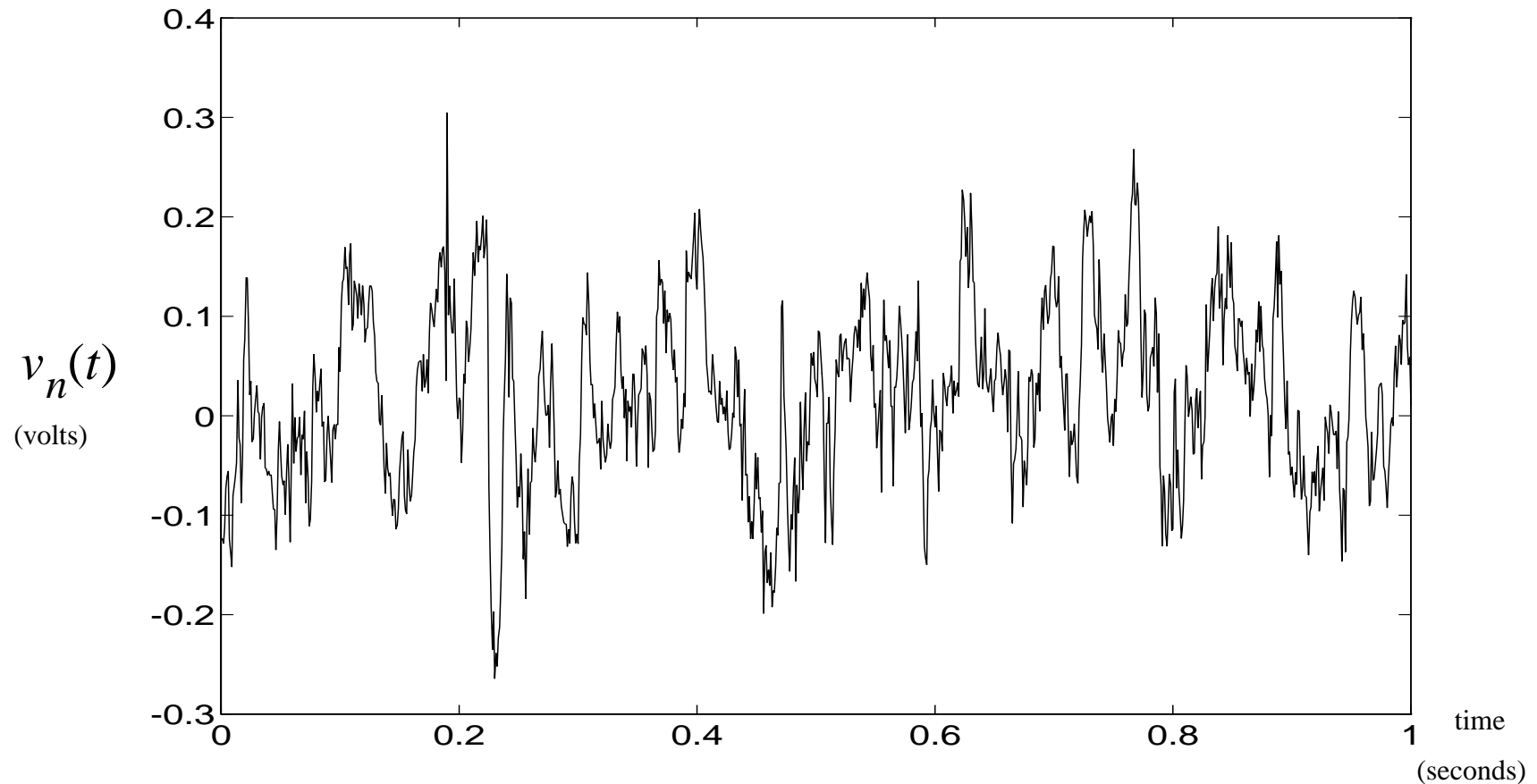

- ***Assume all noise signals have zero mean***



RMS Value

$$V_{n(rms)} \equiv \left[\frac{1}{T} \int_0^T v_n^2(t) dt \right]^{1/2} \quad (1)$$

- T — suitable averaging time interval
- Indicates ***normalized noise power***.
- If $v_n(t)$ applied to 1Ω resistor, average power dissipated, P_{diss} ,

$$P_{diss} = \frac{V_{n(rms)}^2}{1\Omega} = V_{n(rms)}^2 \quad (2)$$



SNR

$$\text{SNR} \equiv 10\log \left[\frac{\text{signal power}}{\text{noise power}} \right] \quad (3)$$

- If signal node has normalized signal power of $V_{x(rms)}^2$, and noise power of $V_{n(rms)}^2$,

$$\text{SNR} = 10\log \left[\frac{V_{x(rms)}^2}{V_{n(rms)}^2} \right] = 20\log \left[\frac{V_{x(rms)}}{V_{n(rms)}} \right] \quad (4)$$

- When mean-squared values of noise and signal are same, $\text{SNR} = 0\text{dB}$.



Units of dBm

- Often useful to know signal's power in dB on absolute scale.
- With dBm, all power levels referenced 1mW.
- 1mW signal corresponds to 0 dBm
- $1\mu\text{W}$ signal corresponds to -30dBm

What if only voltage measured (not power)?

- If voltage measured — reference level to equiv power dissipated if voltage applied to 50 Ω resistor
- Also, can reference it to 75 Ω resistor



dBm Example

- Find rms voltage of 0 dBm signal (50Ω reference)
- What is level in dBm of a 2 volt rms signal?

- 0 dBm signal (50Ω reference) implies

$$V_{(rms)} = \sqrt{(50\Omega) \times 1mW} = 0.2236 \quad (5)$$

- Thus, a 2 volt (rms) signal corresponds to

$$20 \times \log\left(\frac{2.0}{0.2236}\right) = 19 \text{ dBm} \quad (6)$$

- Would dissipate $2^2/50 = 80 \text{ mW}$ across a 50Ω resistor
- 80 mW corresponds to $10\log(80) = 19 \text{ dBm}$



Noise Summation

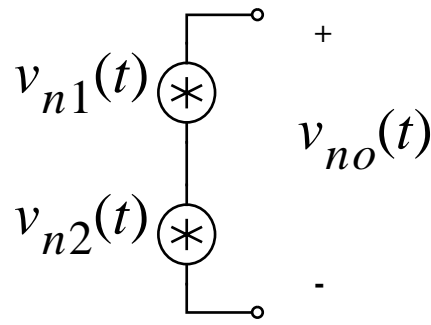

Voltage

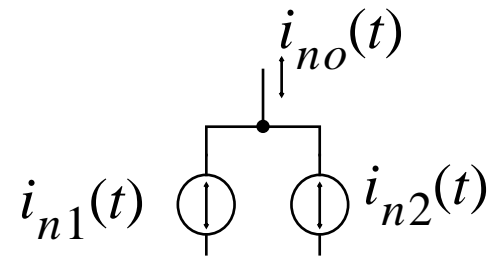

Current

$$v_{no}(t) = v_{n1}(t) + v_{n2}(t) \quad (7)$$

$$V_{no(rms)}^2 = \frac{1}{T} \int_0^T [v_{n1}(t) + v_{n2}(t)]^2 dt \quad (8)$$

$$V_{no(rms)}^2 = V_{n1(rms)}^2 + V_{n2(rms)}^2 + \frac{2}{T} \int_0^T v_{n1}(t)v_{n2}(t)dt \quad (9)$$



Correlation

- Last term relates correlation between two signals
- Define correlation coefficient, C ,

$$C \equiv \frac{\frac{1}{T} \int_0^T v_{n1}(t)v_{n2}(t)dt}{V_{n1(rms)}V_{n2(rms)}} \quad (10)$$

$$V_{no(rms)}^2 = V_{n1(rms)}^2 + V_{n2(rms)}^2 + 2CV_{n1(rms)}V_{n2(rms)} \quad (11)$$

- Correlation always satisfies $-1 \leq C \leq 1$
- $C = +1$ — fully-correlated in-phase (0 degrees)
- $C = -1$ — fully-correlated out-of-phase (180 degrees)
- $C = 0$ — uncorrelated (90 degrees)



Uncorrelated Signals

- *In case of two uncorrelated signals, mean-squared value of sum given by*

$$V_{no(rms)}^2 = V_{n1(rms)}^2 + V_{n2(rms)}^2 \quad (12)$$

- Two rms values add as though they were vectors at right angles

When fully correlated

$$V_{no(rms)}^2 = (V_{n1(rms)} \pm V_{n2(rms)})^2 \quad (13)$$

- sign is determined by whether signals are in or out of phase
- Here, rms values add linearly (aligned vectors)



Noise Summation Example

- $V_{n1(rms)} = 10\mu V$, $V_{n2(rms)} = 5\mu V$, then

$$V_{no(rms)}^2 = (10^2 + 5^2) = 125 \quad (14)$$

which results in $V_{no(rms)} = 11.2\mu V$.

- Note that **eliminating** $V_{n2(rms)}$ noise source same as **reducing** $V_{n1(rms)} = 8.7\mu V$ (i.e. **reducing by 13%**)!

Important Moral

- ***To reduce overall noise, concentrate on large noise signals.***



Frequency-Domain Analysis

- With deterministic signals, frequency-domain techniques are useful.
- Same true for dealing with random signals like noise.
- This section presents frequency-domain techniques for dealing with noise (or random) signals.



Spectral Density

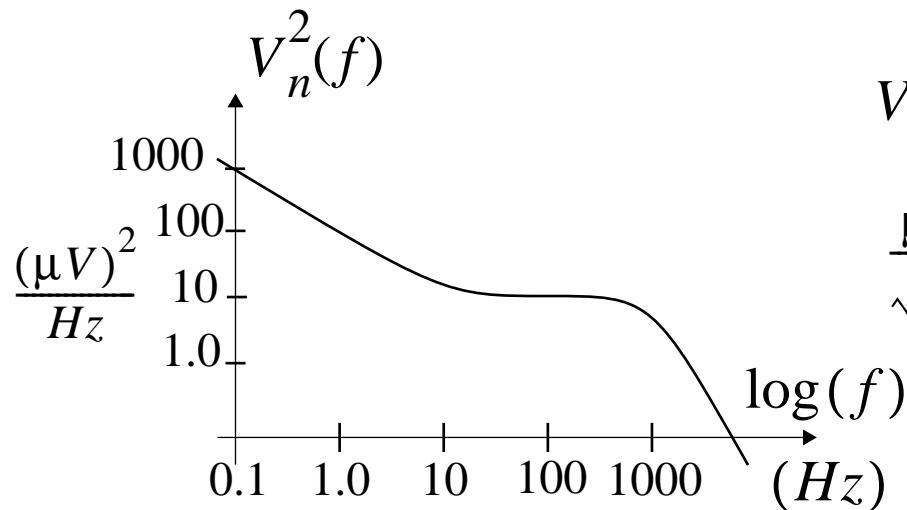

Spectral Density

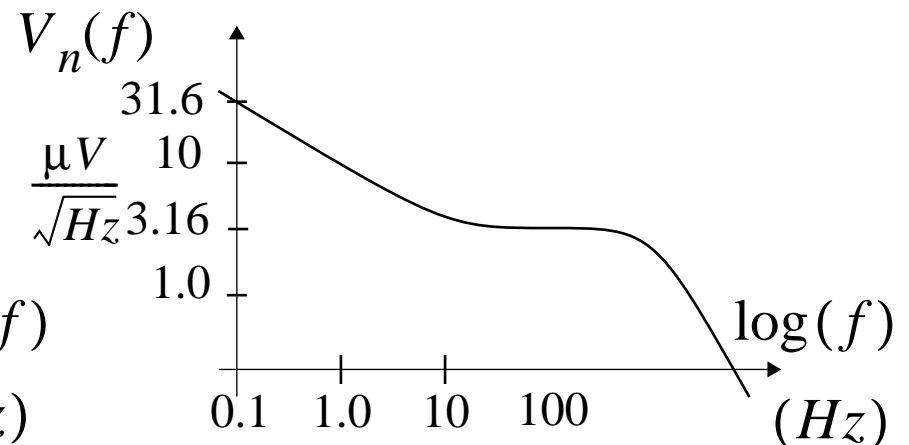

Root-Spectral Density

- Periodic waveforms have their power at distinct frequencies.
- Random signals have their power spread out over the frequency spectrum.



Spectral Density

Spectral Density $V_n^2(f)$

- Average normalized power over a 1 hertz bandwidth
- Units are volts-squared/hertz

Root-Spectral Density $V_n(f)$

- Square root of vertical axis (freq axis unchanged)
- Units are volts/root-hertz (i.e. V/\sqrt{Hz}).

Total Power

$$V_{n(rms)}^2 = \int_0^{\infty} V_n^2(f) df \quad (15)$$

- Above is a one-sided definition (i.e. all power at positive frequencies)



Root-Spectral Density Example

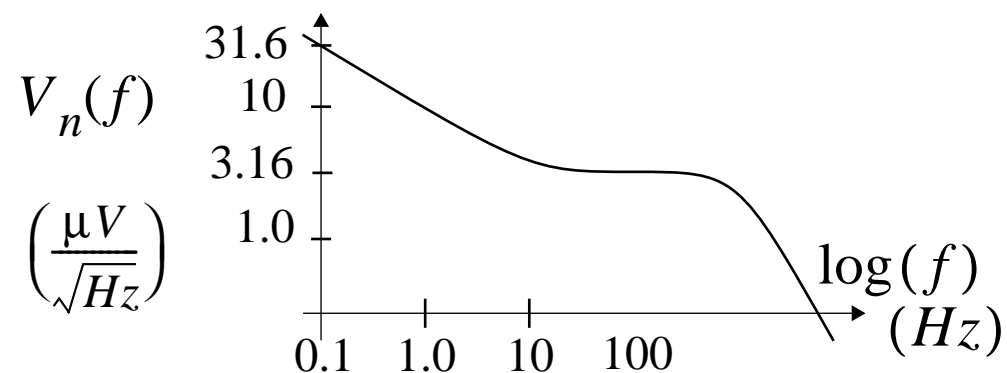

- Around 100 Hz, $V_n(f) = \sqrt{10} \mu\text{V} / \sqrt{\text{Hz}}$
- If measurement used RBW = 30 Hz, measured rms

$$\sqrt{10} \times \sqrt{30} = \sqrt{300} \mu\text{V} \quad (16)$$

- If measurement used RBW = 0.1 Hz, measured rms

$$\sqrt{10} \times \sqrt{0.1} = 1 \mu\text{V} \quad (17)$$



White Noise

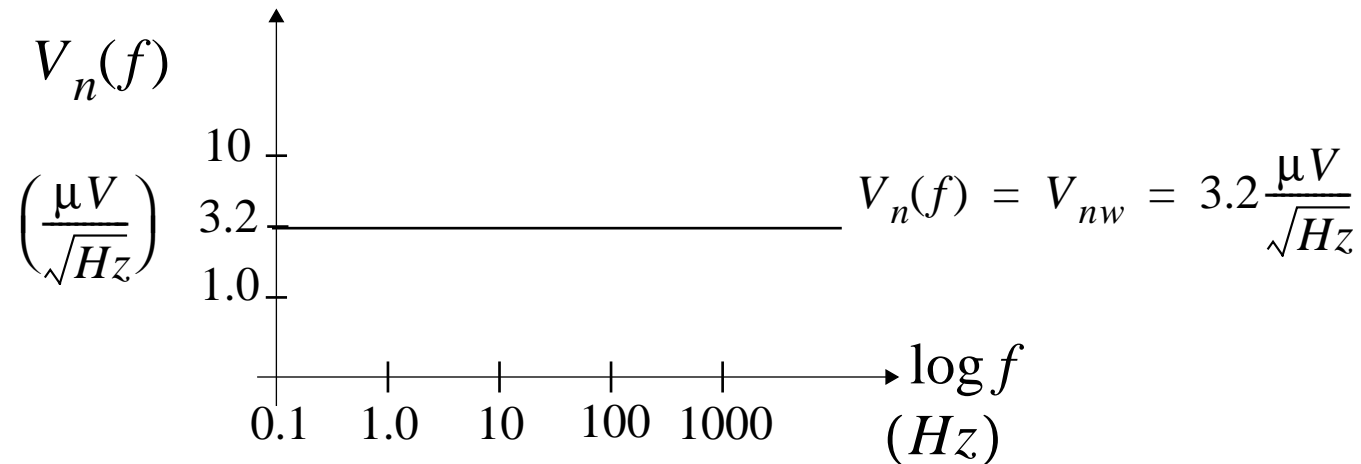

- Noise signal is “white” if a constant spectral density

$$V_n(f) = V_{nw} \quad (18)$$

where V_{nw} is a constant value



1/f Noise

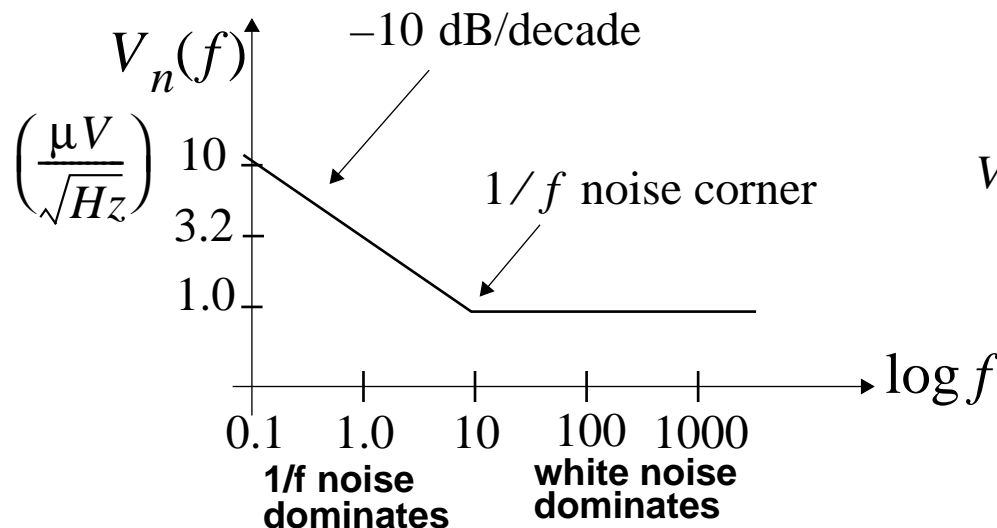

$$V_n^2(f) \approx \frac{(3.2 \times 10^{-6})^2}{f} + (1 \times 10^{-6})^2$$

$$V_n^2(f) = k_v^2 / f \quad (k_v \text{ is a constant}) \quad (19)$$

- In terms of root-spectral density

$$V_n(f) = k_v / \sqrt{f} \quad (20)$$

Falls off at -10 db/decade due to \sqrt{f}

- Also called **flicker** or **pink** noise.



Filtered Noise

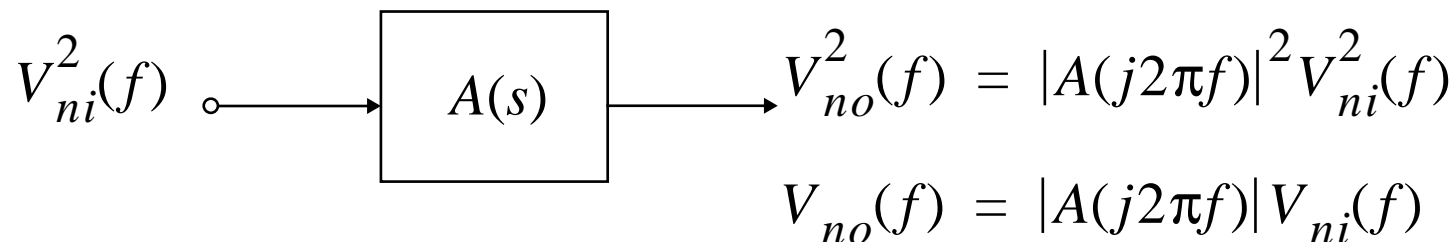

- Output only a function of magnitude of transfer-function ***and not its phase***
- Can always apply an allpass filter without affecting noise performance.
- Total output mean-squared value is

$$V_{no(rms)}^2 = \int_0^{\infty} |A(j2\pi f)|^2 V_{ni}^2(f) df \quad (21)$$



Noise Example

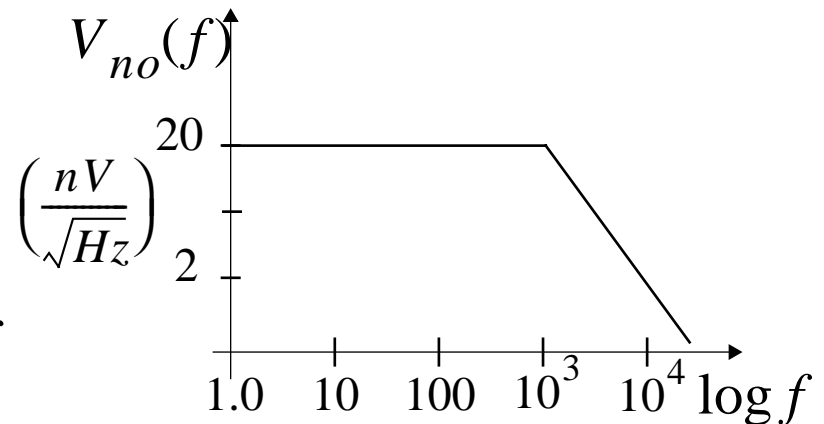
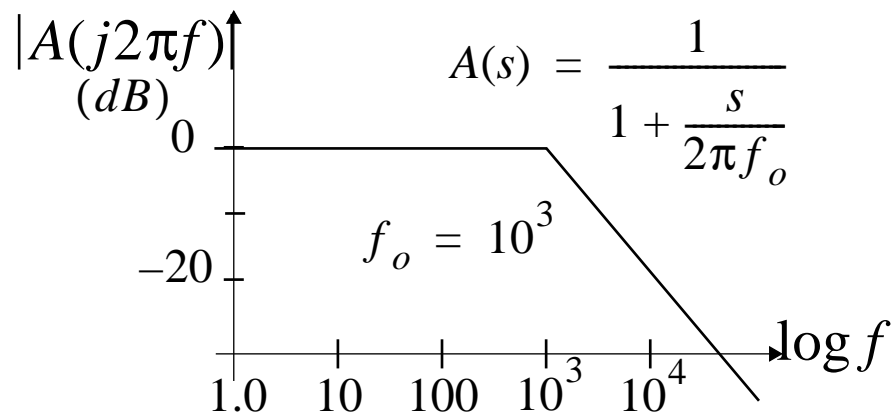
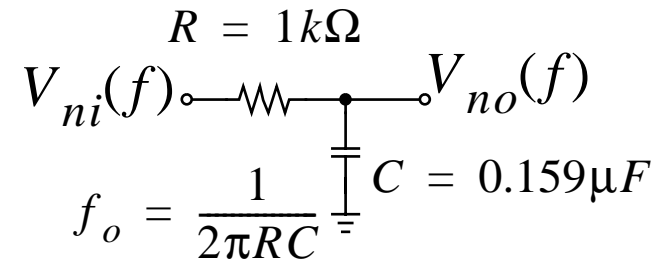
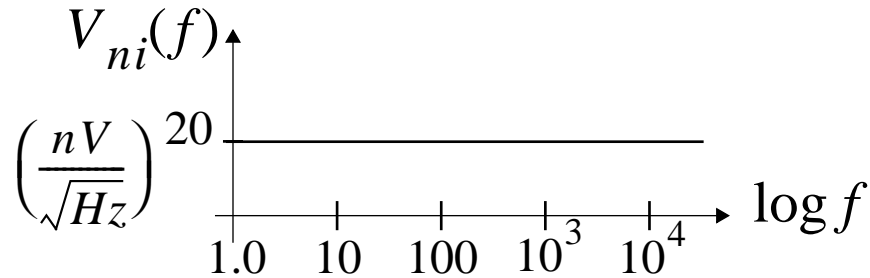

Noise Example

- From dc to 100 kHz of input signal

$$V_{ni(rms)}^2 = \int_0^{10^5} 20^2 df = 4 \times 10^7 (nV)^2 = (6.3 \mu V \text{ rms})^2 \quad (22)$$

- Note: for this simple case,

$$V_{ni(rms)}^2 = 20 \text{ nV} / \sqrt{Hz} \times \sqrt{100kHz} = (6.3 \mu V \text{ rms})^2 \quad (23)$$

- For the filtered signal, $V_{no}(f)$,

$$V_{no}(f) = \frac{20 \times 10^{-9}}{\sqrt{1 + \left(\frac{f}{f_o}\right)^2}} \quad (24)$$



Noise Example

- Between dc and 100kHz

$$\begin{aligned} V_{no(rms)}^2 &= \int_0^{10^5} \frac{20^2}{1 + \left(\frac{f}{f_o}\right)^2} df = 20^2 f_o \operatorname{atan}\left(\frac{f}{f_o}\right) \Big|_0^{10^5} \\ &= 6.24 \times 10^5 (nV)^2 = (0.79 \mu V \text{ rms})^2 \end{aligned} \quad (25)$$

- Noise rms value of $V_{no}(f)$ is almost 1/10 that of $V_{ni}(f)$ since high frequency noise above 1kHz was filtered.
- ***Don't design for larger bandwidths than required otherwise noise performance suffers.***



Sum of Filtered Noise

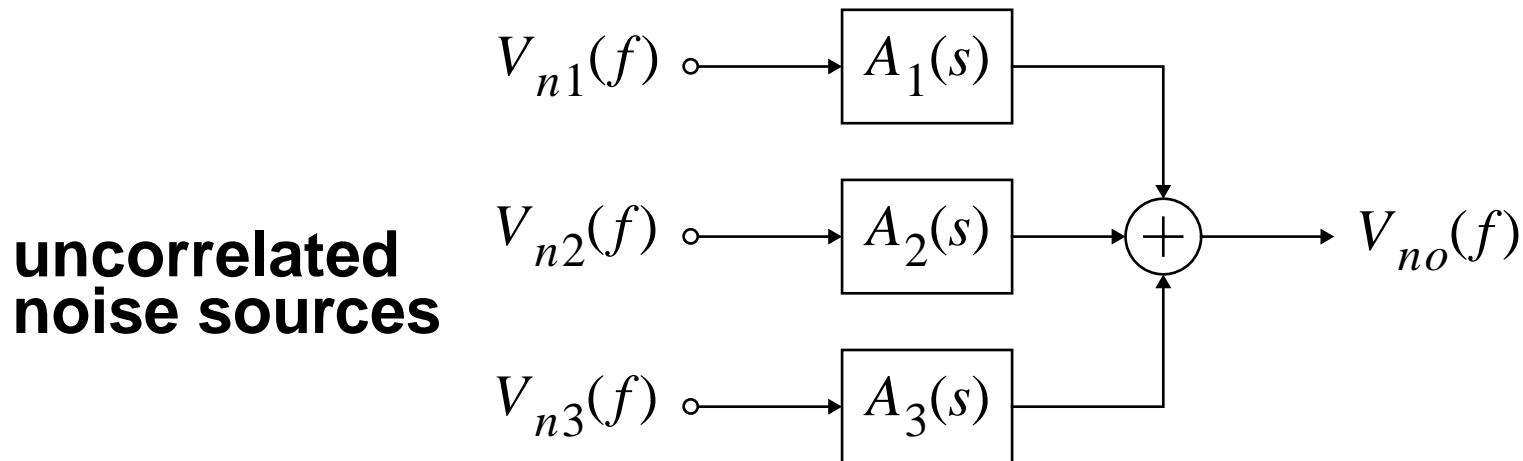

- If filter inputs are uncorrelated, filter outputs are also uncorrelated
- Can show

$$V_{no}^2(f) = \sum_{i=1,2,3} |A_i(j2\pi f)|^2 V_{ni}^2(f) \quad (26)$$



Noise Bandwidth

- Equal to the frequency span of a brickwall filter having the same output noise rms value when white noise is applied to each

Example

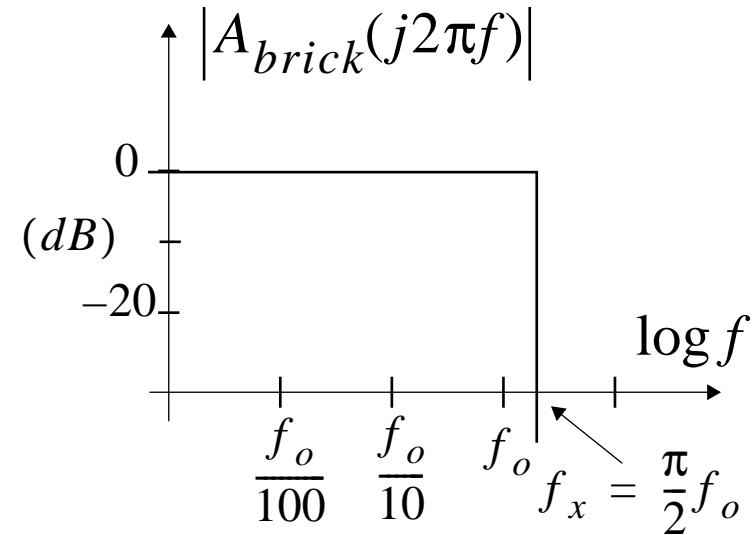
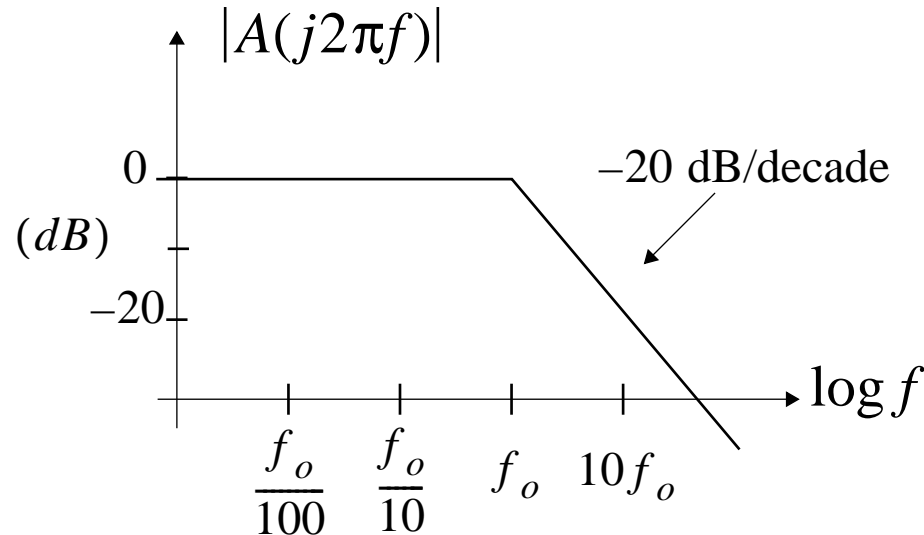

- Noise bandwidth of a 1'st-order filter is $\frac{\pi}{2}f_o$



Noise Bandwidth

- Advantage — total output noise is easily calculated for white noise input.
- If spectral density is V_{nw} volts/root-Hz and noise bandwidth is f_x , then

$$V_{no(rms)}^2 = V_{nw}^2 f_x \quad (27)$$

Example

- A white noise input of $100 \text{ nV}/\sqrt{\text{Hz}}$ applied to a 1'st order filter with 3 dB frequency of 1 MHz

$$V_{no(rms)} = 100 \times 10^{-9} \times \sqrt{\frac{\pi}{2} \times 10^6}$$
$$V_{no(rms)} = 125 \mu\text{V} \quad (28)$$



1/f Noise Tangent Principle

- Method to determine the frequency region(s) that contributes the dominant noise
- Lower a 1/f noise line until it touches the spectral density curve
- The total noise can be approximated by the noise in the vicinity of the 1/f line
- Works because a curve proportional to $1/x$ results in equal power over each decade of frequency



1/f Tangent Example

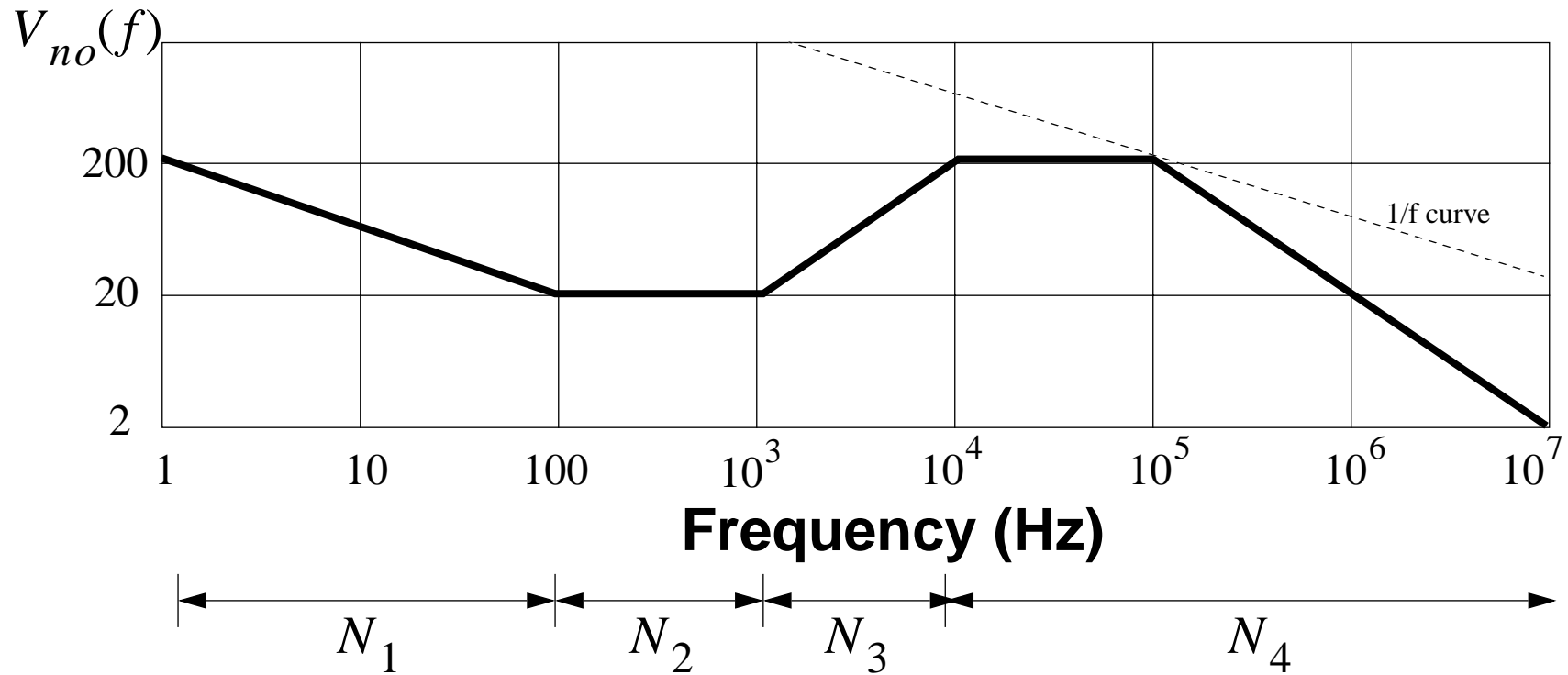

- Consider root-spectral noise density shown above



1/f Tangent Example

$$N_1^2 = \int_1^{100} \frac{200^2}{f} df = 200^2 \ln(f) \Big|_1^{100} = 1.84 \times 10^5 (nV)^2 \quad (29)$$

$$N_2^2 = \int_{100}^{10^3} 20^2 df = 20^2 f \Big|_{100}^{10^3} = 3.6 \times 10^5 (nV)^2 \quad (30)$$

$$N_3^2 = \int_{10^3 (10^3)^2}^{10^4} \frac{20^2 f^2}{(10^3)^2} df = \left(\frac{20}{10^3} \right)^2 \left[\frac{1}{3} f^3 \Big|_{10^3}^{10^4} \right] = 1.33 \times 10^8 (nV)^2 \quad (31)$$

$$N_4^2 = \int_{10^4}^{\infty} \frac{200^2}{1 + \left(\frac{f}{10^5} \right)^2} df = \int_0^{\infty} \frac{200^2}{1 + \left(\frac{f}{10^5} \right)^2} df - \int_0^{10^4} 200^2 df \quad (32)$$

$$= 200^2 \left(\frac{\pi}{2} \right) 10^5 - (200^2)(10^4) = 5.88 \times 10^9 (nV)^2$$



1/f Tangent Example

- The total output noise is estimated to be

$$V_{no(rms)} = (N_1^2 + N_2^2 + N_3^2 + N_4^2)^{1/2} = 77.5\mu V \text{ rms} \quad (33)$$

- But ...

$$N_4 = 76.7\mu V \text{ rms} \quad (34)$$

- Need only have found the noise in the vicinity where the 1/f tangent touches noise curve.
- **Note:** if noise curve is parallel to 1/f tangent for a wide range of frequencies, then also sum that region.



Noise Models for Circuit Elements

- Three main sources of noise:

Thermal Noise

- Due to thermal excitation of charge carriers.
- Appears as white spectral density

Shot Noise

- Due to dc bias current being pulses of carriers
- Dependent of dc bias current and is white.

Flicker Noise

- Due to traps in semiconductors
- Has a $1/f$ spectral density
- Significant in MOS transistors at low frequencies.



Resistor Noise

- Thermal noise — white spectral density

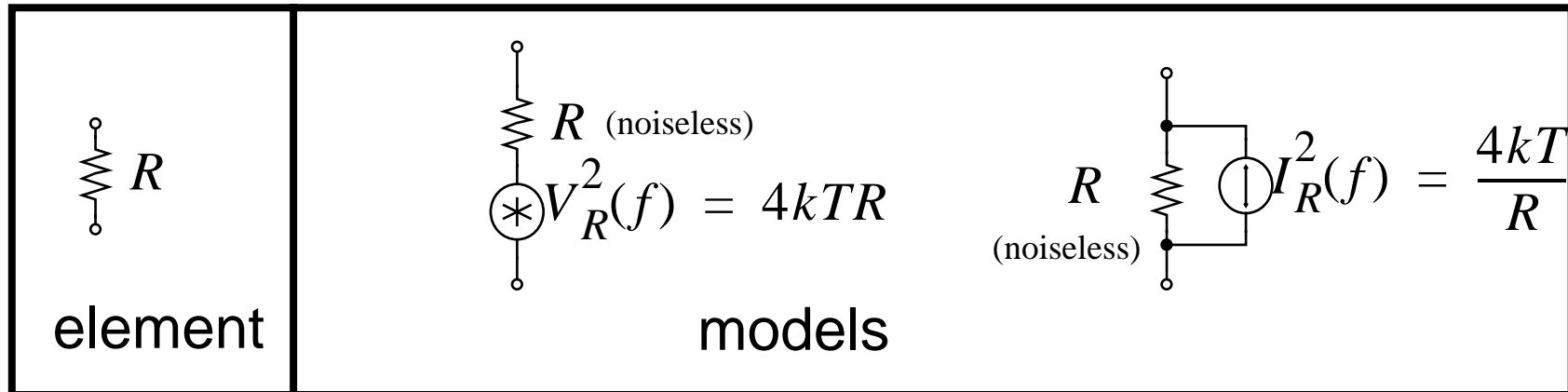

- k is Boltzmann's constant = $1.38 \times 10^{-23} \text{ JK}^{-1}$
- T is the temperature in degrees Kelvin
- Can also write

$$V_R(f) = \sqrt{\frac{R}{1k}} \times 4.06 \text{ nV} / \sqrt{\text{Hz}} \quad \text{for } 27^\circ\text{C} \quad (35)$$



Diodes

- Shot noise — white spectral density

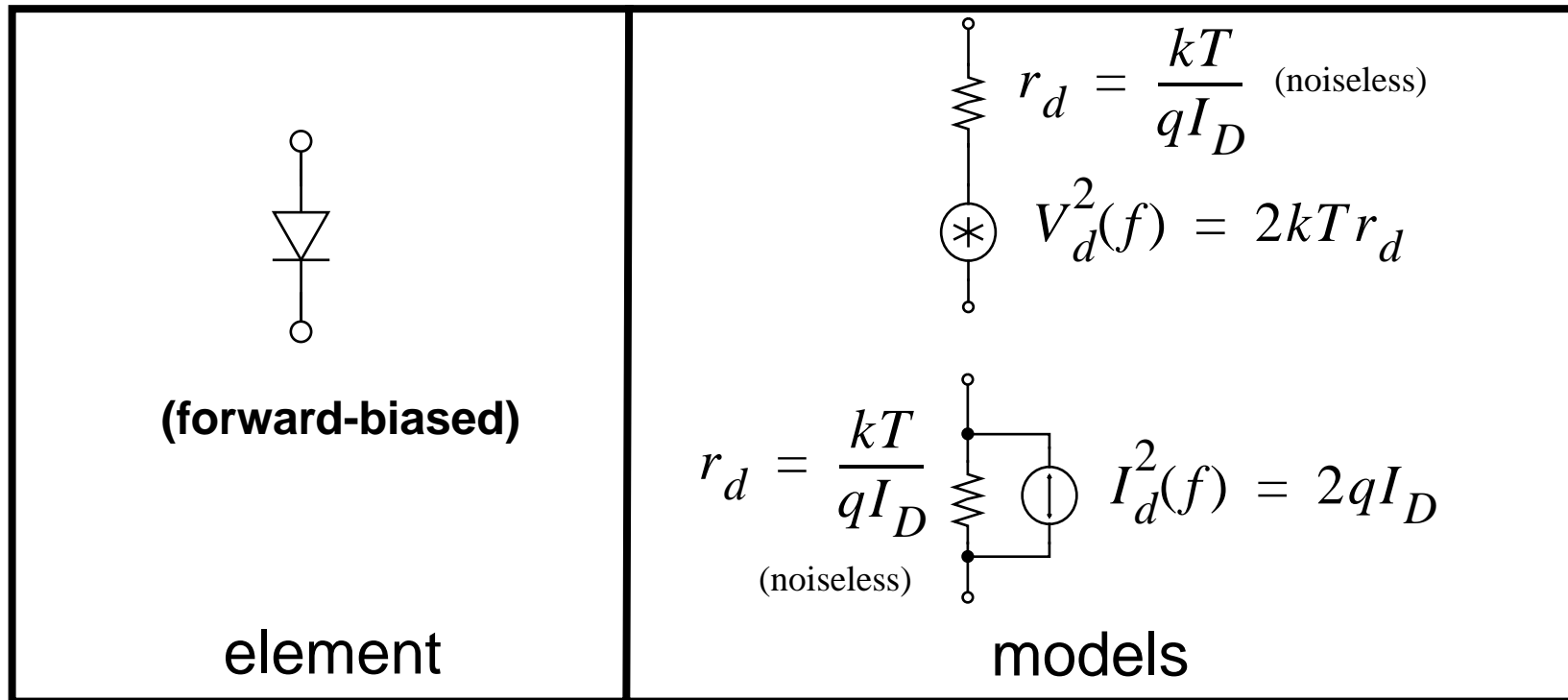

- q is one electronic charge = 1.6×10^{-19} C
- I_D is the dc bias current through the diode



Bipolar Transistors

- Shot noise of collector and base currents
- Flicker noise due to base current
- Thermal noise due to base resistance

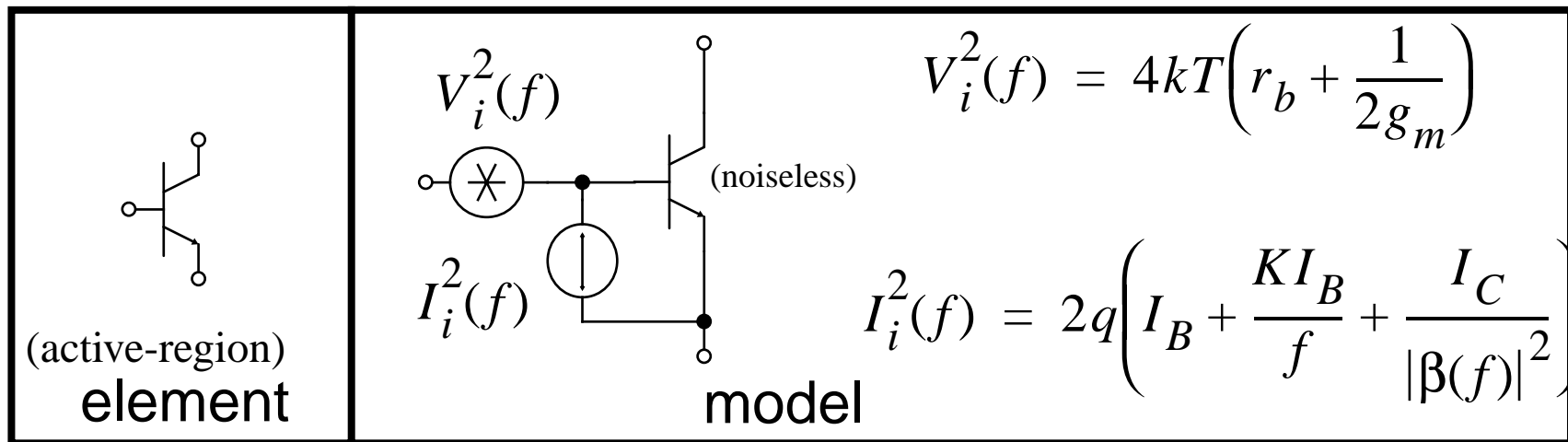

- $V_i(f)$ has base resistance thermal noise plus collector shot noise referred back
- $I_i(f)$ has base shot noise, base flicker noise plus collector shot noise referred back



MOSFETS

- Flicker noise at gate
- Thermal noise in channel

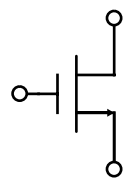

(active-region)

element

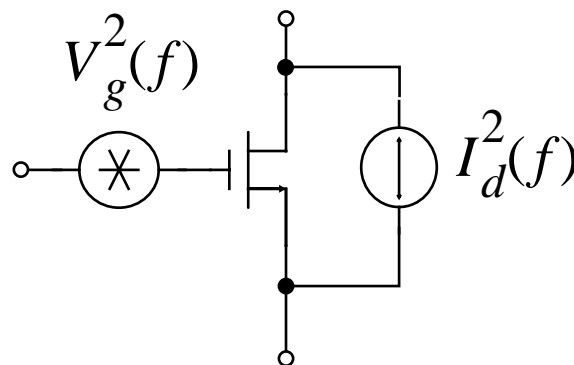

$$V_g^2(f) = \frac{K}{WLC_{ox}f}$$

$$I_d^2(f) = 4kT\left(\frac{2}{3}\right)g_m$$

model



MOSFET Flicker (1/f) Noise

$$V_g^2(f) = \frac{K}{WLC_{ox}f} \quad (36)$$

- K dependent on device characteristics, varies widely.
- W & L — Transistor's width and length
- C_{ox} — gate-capacitance/unit area
- ***Flicker noise is inversely proportional to the transistor area, WL .***
- 1/f noise is extremely important in MOSFET circuits as it can dominate at low-frequencies
- Typically p-channel transistors have less noise since holes are less likely to be trapped.



MOSFET Thermal Noise

- Due to resistive nature of channel
- In triode region, noise would be $I_d^2(f) = (4kT)/r_{ds}$ where r_{ds} is the channel resistance
- In active region, channel is not homogeneous and total noise is found by integration

$$I_d^2(f) = 4kT \left(\frac{2}{3} \right) g_m \quad (37)$$

for the case $V_{DS} = V_{GS} - V_T$

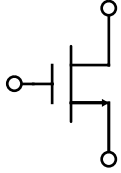
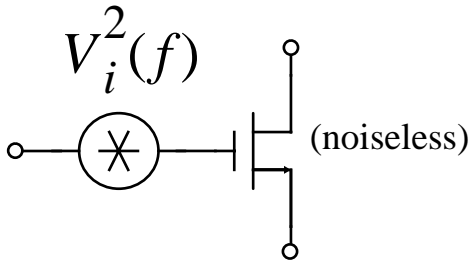

Low-Moderate Frequency MOSFET Model

 <p>(active-region) element</p>	 <p>(noiseless)</p> $V_i^2(f) = 4kT \left(\frac{2}{3} \right) \frac{1}{g_m} + \frac{K}{WLC_{ox}f}$ <p>model</p>
--	--

- Can lump thermal noise plus flicker noise as an input voltage noise source at low to moderate frequencies.
- At high frequencies, gate current can be appreciable due to capacitive coupling.



Opamps

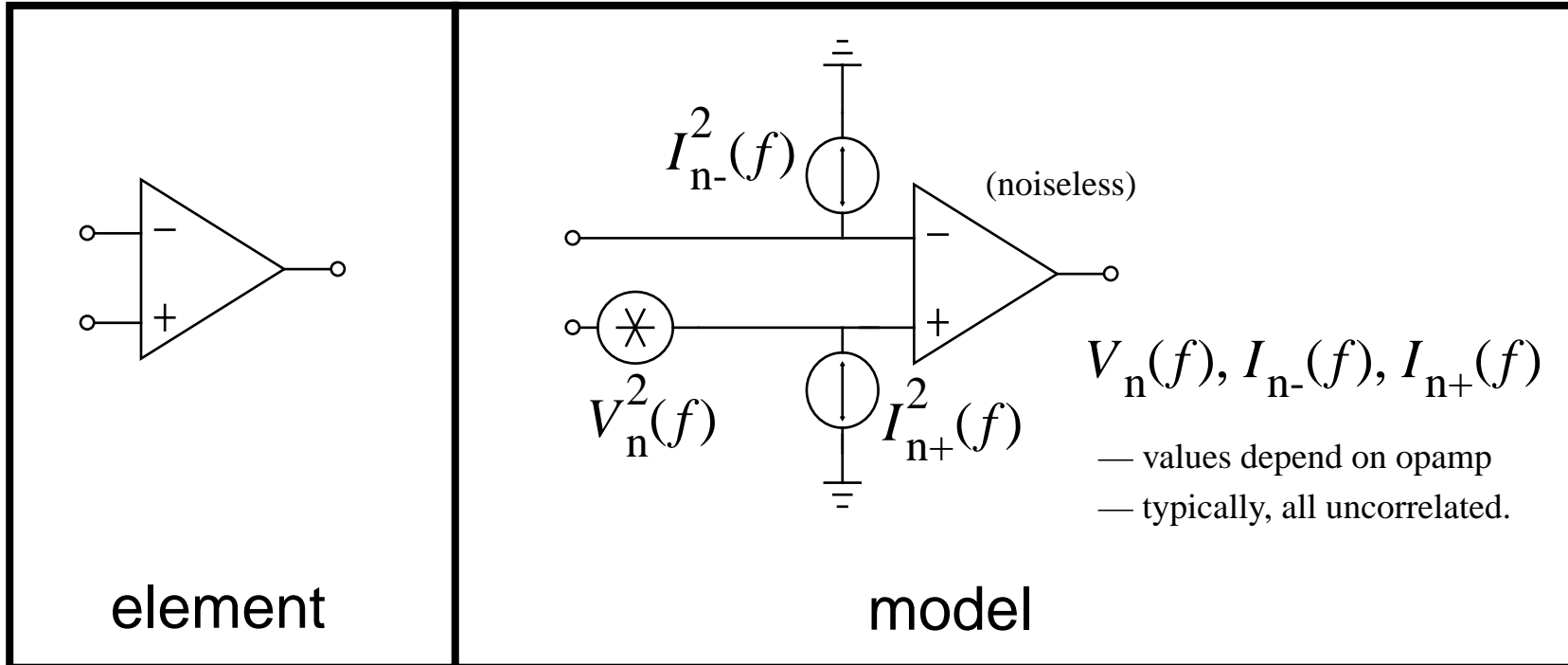

- Modelled as 3 uncorrelated input-referred noise sources.
- Current sources often ignored in MOSFET opamps



Why 3 Noise Sources?

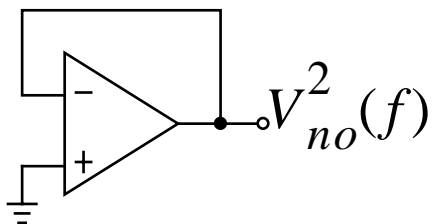

$$V_n(f) \text{ ignored} \Rightarrow V_{no}^2 = 0$$

$$\text{Actual } V_{no}^2 = V_n^2$$

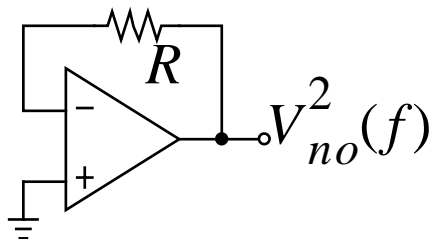

$$I_{n-}(f) \text{ ignored} \Rightarrow V_{no}^2 = V_n^2$$

$$\text{Actual } V_{no}^2 = V_n^2 + (I_{n-}R)^2$$

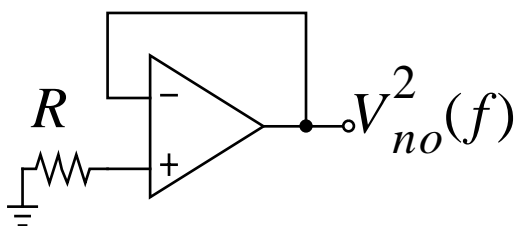

$$I_{n+}(f) \text{ ignored} \Rightarrow V_{no}^2 = V_n^2$$

$$\text{Actual } V_{no}^2 = V_n^2 + (I_{n+}R)^2$$



Capacitors

- Capacitors and inductors do not generate any noise but ... they accumulate noise.
- Capacitor noise mean-squared value equals kT/C when connected to an arbitrary resistor value.

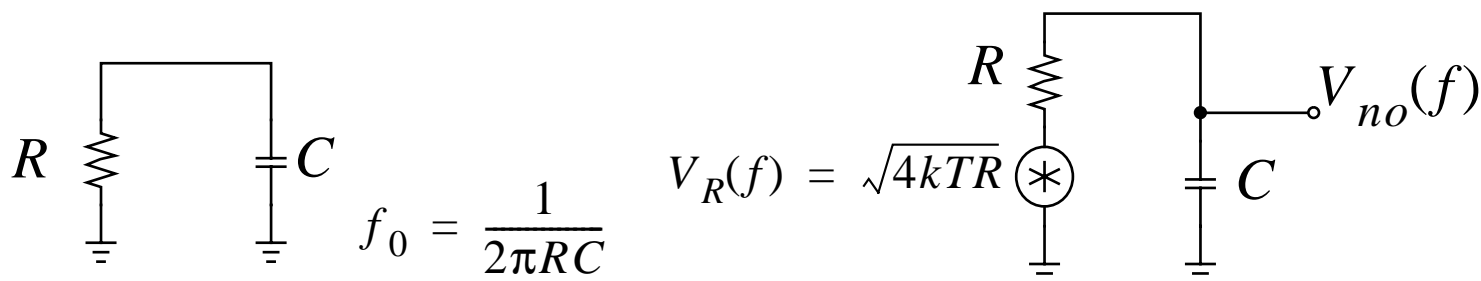

- Noise bandwidth equals $(\pi/2)f_o$

$$V_{no(rms)}^2 = V_R^2(f) \left(\frac{\pi}{2} \right) f_o = (4kTR) \left(\frac{\pi}{2} \right) \left(\frac{1}{2\pi RC} \right)$$

$$V_{no(rms)}^2 = \frac{kT}{C} \quad (38)$$



Capacitor Noise Example

- At 300 °K, what capacitor size is needed to have 96dB dynamic range with 1 V rms signal levels.
- Noise allowed:

$$V_{n(rms)} = \frac{1V}{10^{96/20}} = 15.8 \mu V \text{ rms} \quad (39)$$

- Therefore

$$C = \frac{kT}{V_{n(rms)}^2} = 16.6 pF \quad (40)$$

- This min capacitor size determines max resistance size to achieve a given time-constant.



Sampled Signal Noise

- Consider basic sample-and-hold circuit

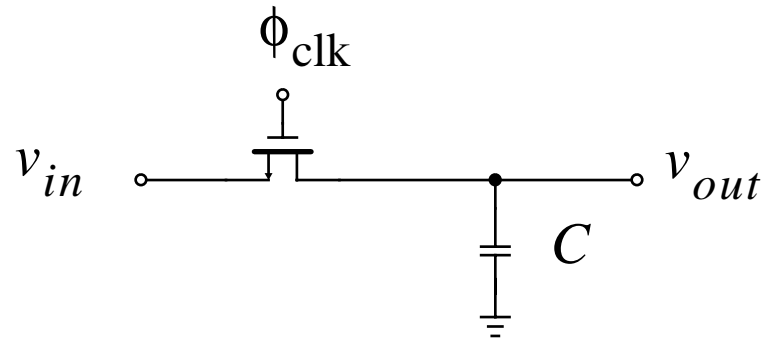

-
- When ϕ_{clk} goes low, noise as well as signal is held on C . — an rms noise voltage of $\sqrt{kT/C}$.
- Does not depend on sampling rate and is independent from sample to sample.
- Can use “oversampling” to reduce effective noise.
- Sample, say 1000 times, and average results.



Opamp Example

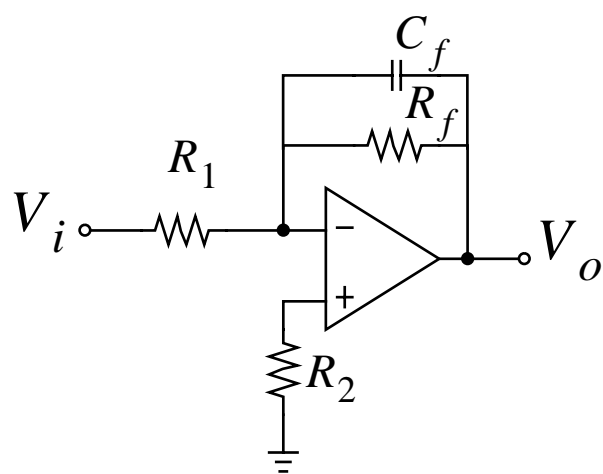

circuit

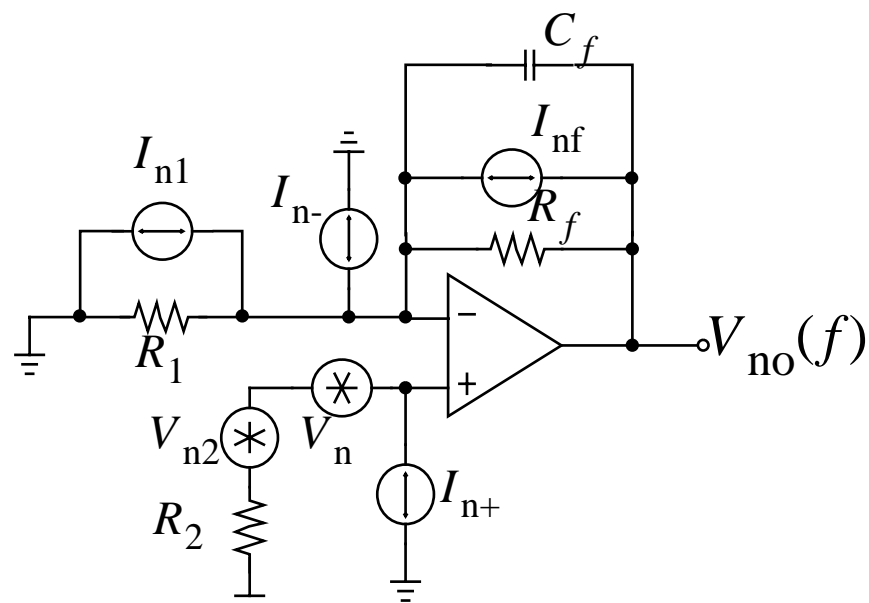

equivalent noise circuit

- Use superposition — noise sources uncorrelated
- Consider I_{n1} , I_{nf} and I_{n-} causing $V_{no1}^2(f)$

$$V_{no1}^2(f) = (I_{n1}^2(f) + I_{nf}^2(f) + I_{n-}^2(f)) \left| \frac{R_f}{1 + j2\pi f R_f C_f} \right|^2 \quad (41)$$



Opamp Example

- Consider I_{n+} , V_{n2} and V_n causing $V_{no2}^2(f)$

$$V_{no2}^2(f) = (I_{n+}^2(f)R_2^2 + V_{n2}^2(f) + V_n^2(f)) \left| 1 + \frac{R_f/R_1}{1 + j2\pi f C_f R_f} \right|^2 \quad (42)$$

- If $R_f \ll R_1$ then gain $\cong 1$ for all freq and ideal opamp would result in infinite noise — practical opamp will lowpass filter noise at opamp f_t .
- If $R_f \gg R_1$, low freq gain $\cong R_f/R_1$ and $f_{3dB} = 1/(2\pi R_f C_f)$ similar to noise at negative input — however, gain falls to unity until opamp f_t .

$$\text{Total noise: } V_{no(rms)}^2 = V_{no1(rms)}^2 + V_{no2(rms)}^2 \quad (43)$$



Numerical Example

- Estimate total output noise rms value for a 10kHz lowpass filter when $C_f = 160\text{pF}$, $R_f = 100\text{k}$, $R_1 = 10\text{k}$, and $R_2 = 9.1\text{k}$.
- Assume $V_n(f) = 20\text{ nV}/\sqrt{\text{Hz}}$, $I_n(f) = 0.6\text{ pA}/\sqrt{\text{Hz}}$ opamp's $f_t = 5\text{ MHz}$.
- Assuming room temperature,

$$I_{\text{nf}} = 0.406\text{ pA}/\sqrt{\text{Hz}} \quad (44)$$

$$I_{\text{n1}} = 1.28\text{ pA}/\sqrt{\text{Hz}} \quad (45)$$

$$V_{\text{n2}} = 12.2\text{ nV}/\sqrt{\text{Hz}} \quad (46)$$



Numerical Example

- The low freq value of $V_{no1}^2(f)$ is found by $f = 0$, in (41).

$$\begin{aligned} V_{no1}^2(0) &= (I_{n1}^2(0) + I_{nf}^2(0) + I_{n-}^2(0))R_f^2 \\ &= (0.406^2 + 1.28^2 + 0.6^2)(1 \times 10^9)^2 (100k)^2 \\ &= (147 \text{ nV}/\sqrt{\text{Hz}})^2 \end{aligned} \tag{47}$$

- Since (41) indicates noise is first-order lowpass filtered,

$$\begin{aligned} V_{no1(\text{rms})}^2 &= (147 \text{ nV}/\sqrt{\text{Hz}})^2 \times \frac{\pi/2}{2\pi(100k\Omega)(160pF)} \\ &= (18.4 \mu\text{V})^2 \end{aligned} \tag{48}$$



Numerical Example

- For $V_{\text{no2}}^2(0)$

$$\begin{aligned}
 V_{\text{no2}}^2(0) &= (I_{\text{n+}}^2(f)R_2^2 + V_{\text{n2}}^2(f) + V_{\text{n}}^2(f))(1 + R_f/R_1)^2 \\
 &= (24.1 \text{ nV}/\sqrt{\text{Hz}})^2 \times 11^2 \\
 &= (265 \text{ nV}/\sqrt{\text{Hz}})^2
 \end{aligned} \tag{49}$$

- Noise is lowpass filtered at f_o until $f_1 = (R_f/R_1)f_o$ where the noise gain reaches unity until $f_t = 5\text{MHz}$
- Breaking noise into two portions, we have

$$\begin{aligned}
 V_{\text{no2(rms)}}^2 &= (265 \times 10^{-9})^2 \left(\frac{\pi/2}{2\pi R_f C_f} \right) + (24.1 \times 10^{-9})^2 \left(\frac{\pi}{2} \right) (f_t - f_1) \\
 &= (74.6 \text{ }\mu\text{V})^2
 \end{aligned} \tag{50}$$



Numerical Example

- Total output noise is estimated to be

$$V_{\text{no(rms)}} = \sqrt{V_{\text{no1(rms)}}^2 + V_{\text{no2(rms)}}^2} = 77 \mu\text{V rms} \quad (51)$$

- Note: major noise source is opamp's voltage noise.
- To reduce total output noise
 - use a lower speed opamp
 - choose an opamp with a lower voltage noise.
- Note: R_2 contributes to output noise with its thermal noise AND amplifying opamp's positive noise current.
- If dc offset can be tolerated, it should be eliminated in a low-noise circuit.



CMOS Example

$$\left| \frac{V_{no}}{V_{n1}} \right| = \left| \frac{V_{no}}{V_{n2}} \right| = g_{m1} R_o \quad (52)$$

where R_o is the output impedance seen at V_{no} .

$$\left| \frac{V_{no}}{V_{n3}} \right| = \left| \frac{V_{no}}{V_{n4}} \right| = g_{m3} R_o \quad (53)$$

$$\left| \frac{V_{no}}{V_{n5}} \right| = \frac{g_{m5}}{2g_{m3}} \quad (54)$$

- Found by noting that V_{n5} modulates bias current and drain of Q_2 tracks that of Q_1 due to symmetry — this gain is small (compared to others) and is ignored.



CMOS Example

$$V_{no}^2(f) = 2(g_{m1}R_o)^2 V_{n1}^2(f) + 2(g_{m3}R_o)^2 V_{n3}^2(f) \quad (55)$$

- Find equiv input noise by dividing by $g_{m1}R_o$

$$V_{neq}^2(f) = 2V_{n1}^2(f) + 2V_{n3}^2(f) \left(\frac{g_{m3}}{g_{m1}} \right)^2 \quad (56)$$

Thermal Noise Portion

- For white noise portion, substitute

$$V_{ni}^2(f) = 4kT \left(\frac{2}{3} \right) \left(\frac{1}{g_{mi}} \right) \quad (57)$$

$$V_{neq}(f) = \left(\frac{16}{3} \right) kT \left(\frac{1}{g_{m1}} \right) + \left(\frac{16}{3} \right) kT \left(\frac{g_{m3}}{g_{m1}} \right) \left(\frac{1}{g_{m1}} \right) \quad (58)$$



CMOS Example

- Assuming g_{m3}/g_{m1} is near unity, near equal contribution of noise from the two pairs of transistors which is inversely proportional to g_{m1} .
- ***In other words, g_{m1} should be made as large as possible to minimize thermal noise contribution.***

1/f Noise Portion

- We make the following substitution into (56),

$$g_{mi} = \sqrt{2\mu_i C_{ox} \left(\frac{W}{L}\right)_i I_{Di}} \quad (59)$$

$$V_{ni}^2(f) = 2V_{n1}^2(f) + 2V_{n3}^2(f) \left(\frac{(W/L)_3 \mu_n}{(W/L)_1 \mu_p} \right) \quad (60)$$



CMOS Example

- Now, letting each of the noise sources have a spectral density

$$V_{ni}^2(f) = \frac{K_i}{W_i L_i C_{ox} f} \quad (61)$$

we have

$$V_{ni}^2(f) = \frac{2}{C_{ox} f} \left(\frac{K_1}{W_1 L_1} + \left(\frac{\mu_n}{\mu_p} \right) \left(\frac{K_3 L_1}{W_1 L_3^2} \right) \right) \quad (62)$$

- Recall first term is due to p-channel input transistors, while second term is due to the n-channel loads



CMOS Example

Some points for low 1/f noise

- For $L_1 = L_3$, the noise of the n-channel loads dominate since $\mu_n > \mu_p$ and typically n-channel transistors have larger 1/f noise than p-channels (i.e. $K_3 > K_1$).
- Taking L_3 longer greatly helps due to the inverse squared relationship — this will limit the signal swings somewhat
- The input noise is independent of W_3 and therefore one can make it large to maximize signal swing at the output.



CMOS Example

Some points for low $1/f$ noise

- Taking W_1 wider also helps to minimize $1/f$ noise (recall it helps white noise as well).
- Taking L_1 longer increases the noise due to the second term being dominant.

